

# TapeMaster Configuration

How you currently manage your Volumes within your business structure determines what configuration is used when setting up TapeMaster for your company.

As Volumes cannot be moved between Customers careful consideration needs to be applied on how to set the Owner, Customers and Media types in TapeMaster. Getting the setup correct the in the first instance will not only save you time but also have TapeTrack conform to your Volume handling processes, instead of you having to adjust to fit the software.

## Common Scenarios And Configuration

TapeTrack is a highly customizable software product and the initial configuration depends on your business model.

Setup is divided into three sections on the Customer Tree in TapeMaster:

- Owner
- Customer
- Media

The owner is fairly self-explanatory, the business that owns the software. This value is used as part of the license key creation, so why it can be changed at any stage a new license key will be required if it is.

What constitutes a Customer varies by the setup required, but essentially is a self contained group of Volumes.

Media classes separate different types of media to simplify tape management and reporting.

## Offsite Vaulting Business

Offsite vaulting is probably the easiest model to plan out.

Lets use the example of an offsite vaulting business called Granite Vaulting. So the owner of the TapeTrack installation is Granite Vaulting.

Granite vaulting then has several data companies that use them for offsite Volume storage. These companies are now included in TapeMaster as Customer, each company being an individual Customer in TapeTrack because although all Customers send their Volumes to the vault, they are always kept within their own pools and never shared between each other.

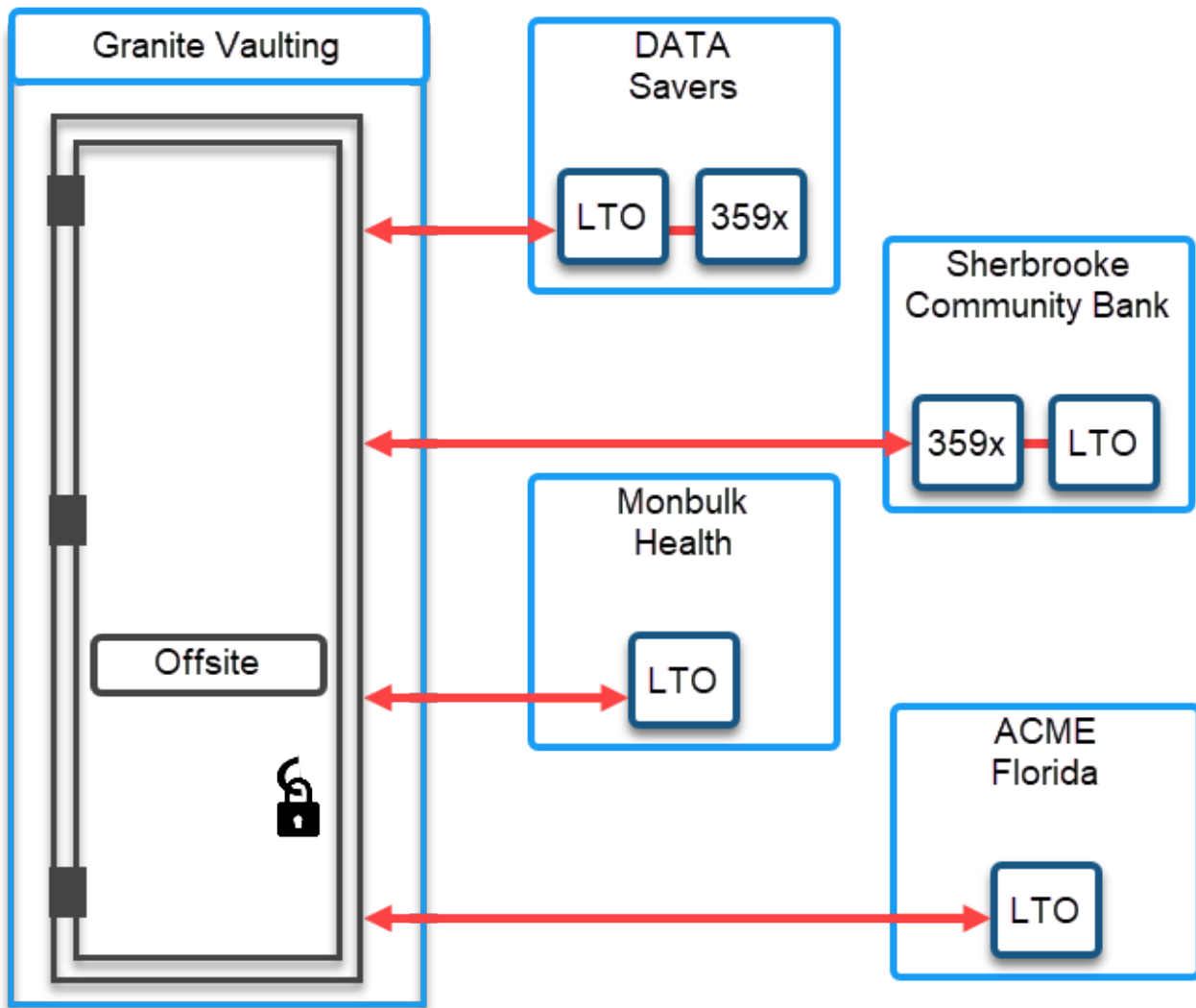

Granite Vaulting has four clients that they currently vault for:

- Data Savers
- Sherbrooke Community Bank
- Monbulk Health
- ACME Florida

These Clients are listed in TapeMaster as Customers. The Customers are then assigned media types based on what Media types are vaulted.

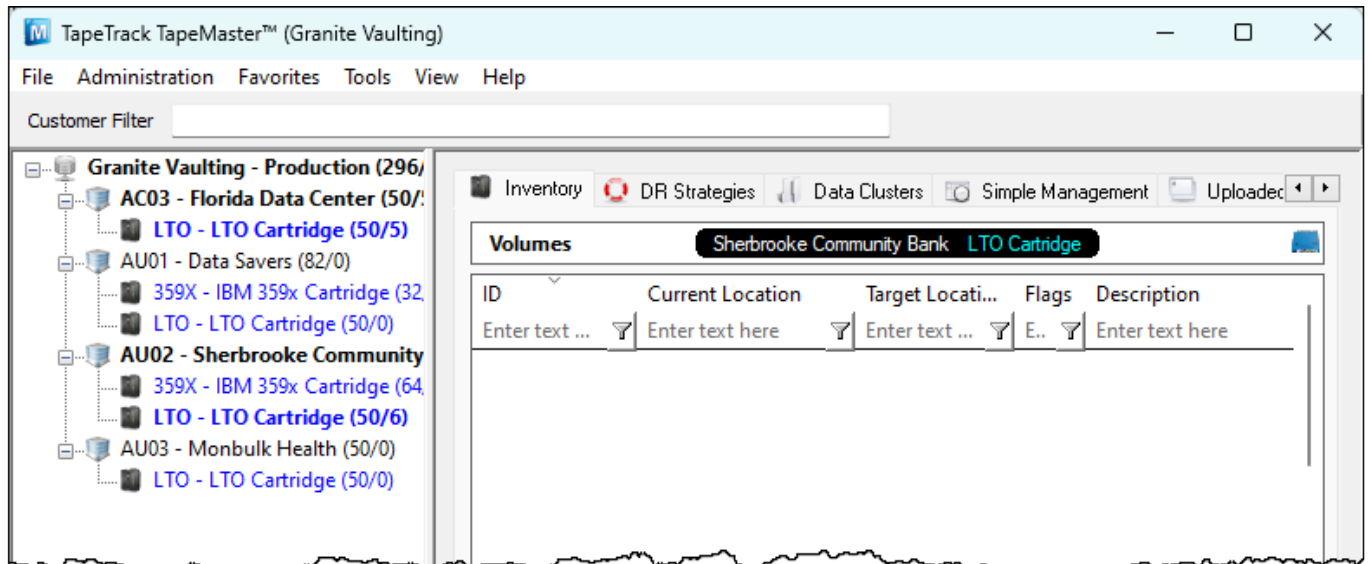

As new clients are procured, a new Customer is added to TapeMaster for each of them.

Now that we have the Customers added, the next step is to add locations on where the Volumes can be in the Volume cycle between the vault and the Customers. The different locations the Volumes can be, are represented in TapeMaster as Repositories. Each Repository depicts one location, in this case either at the vault or at the Customer. Although the Customers may have many locations (Library, GemTracs, Scratch racking etc) it makes no difference to the vault where the Customer places the Volumes when they have them, only whether they are at or in transit to or from, the vault or the customer.

Two Repositories are added to each Customers Media types:

- Granite Vaulting
- Customer

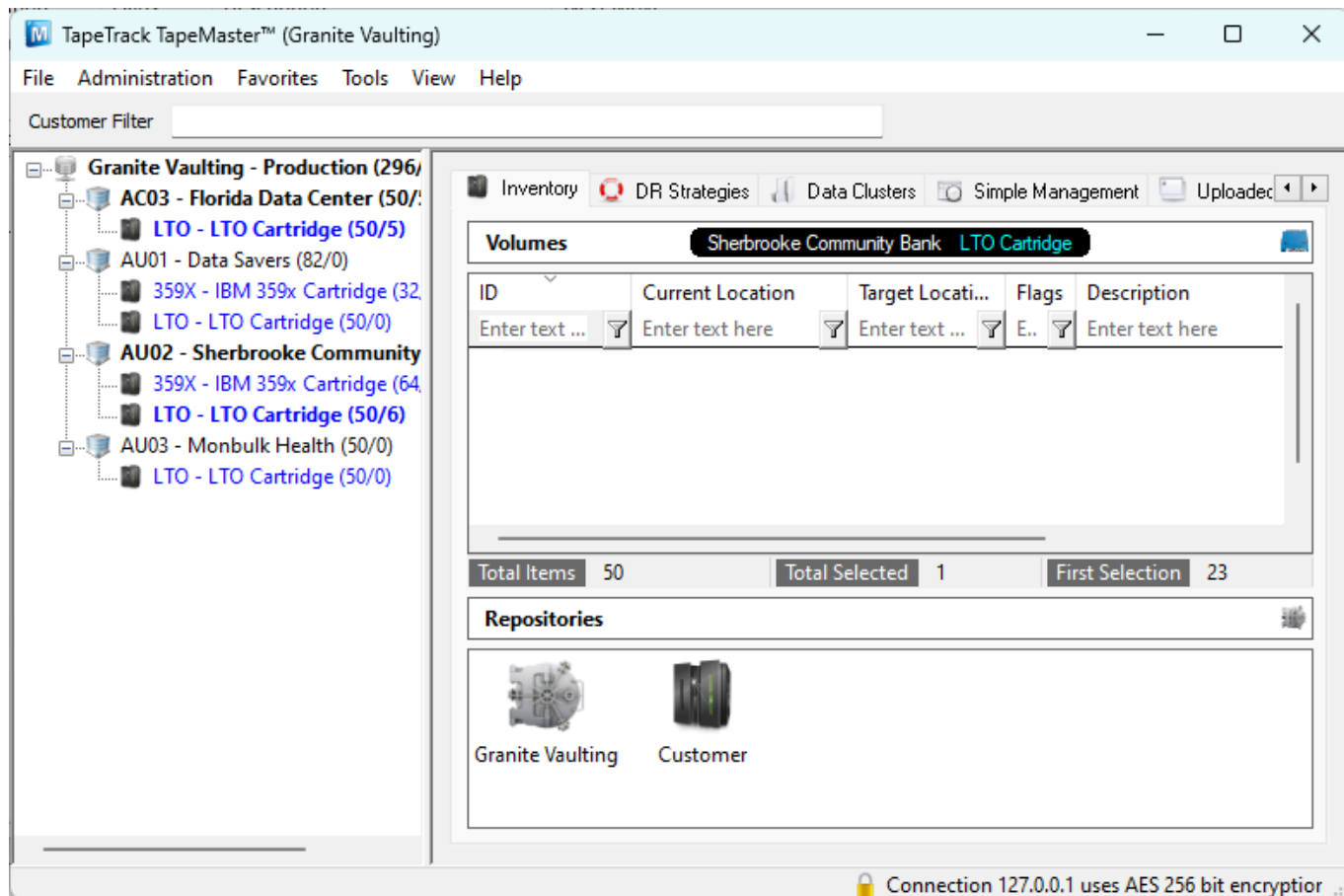

## Data Business

For this example we are going to use a data business ACME Corporation, as a company has three different locations around the country, Los Angeles, New York and Florida. Each of these locations have their own pool of Volumes and do not share use of those Volumes. This example also works for a business with just the one location.

Different locations use varying media types and all vault externally.

The owner of the TapeTrack installation is ACME Corporation.

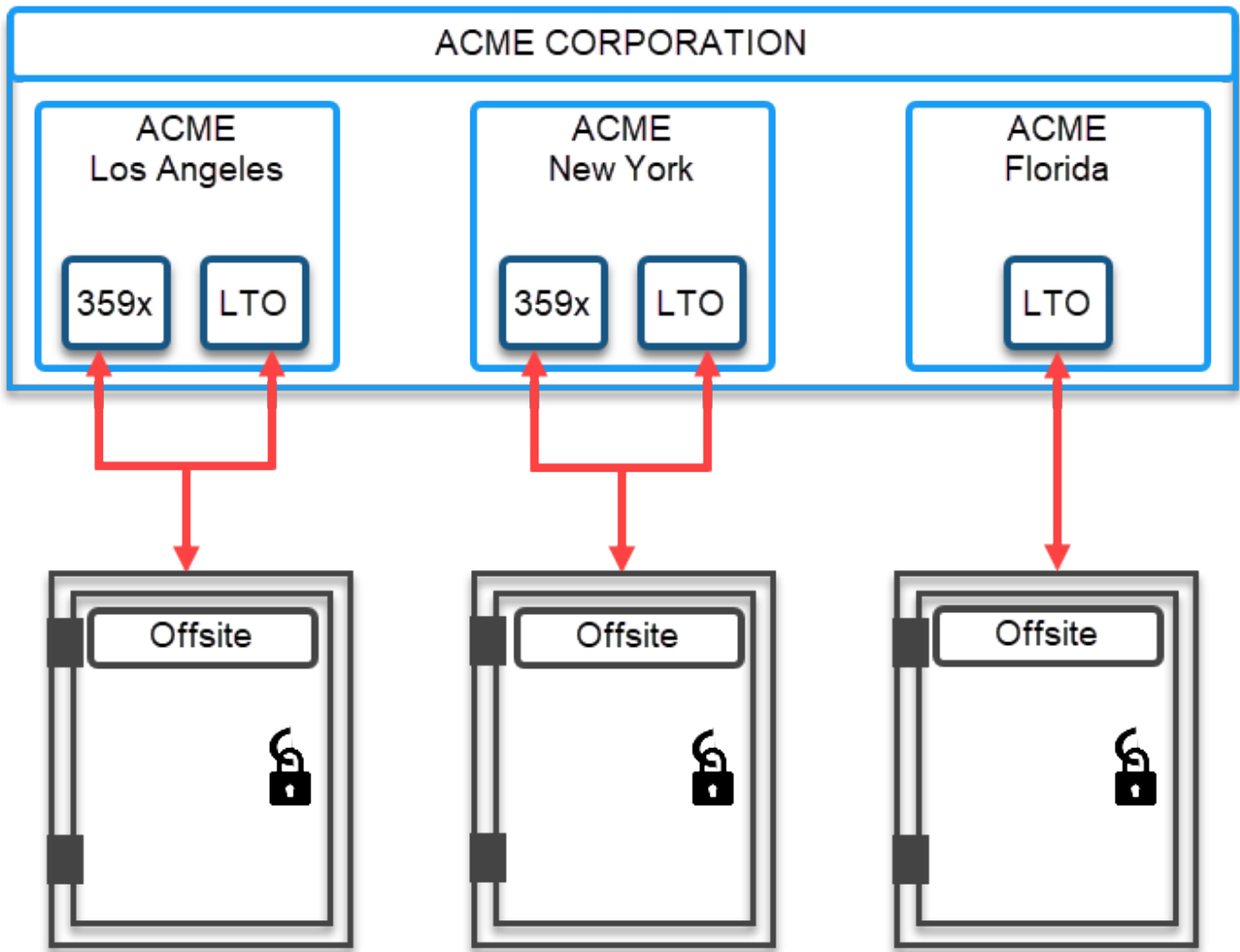

Each of ACME's locations are listed in TapeMaster as Customers. The Customers are then assigned media types based on what Media types are vaulted.

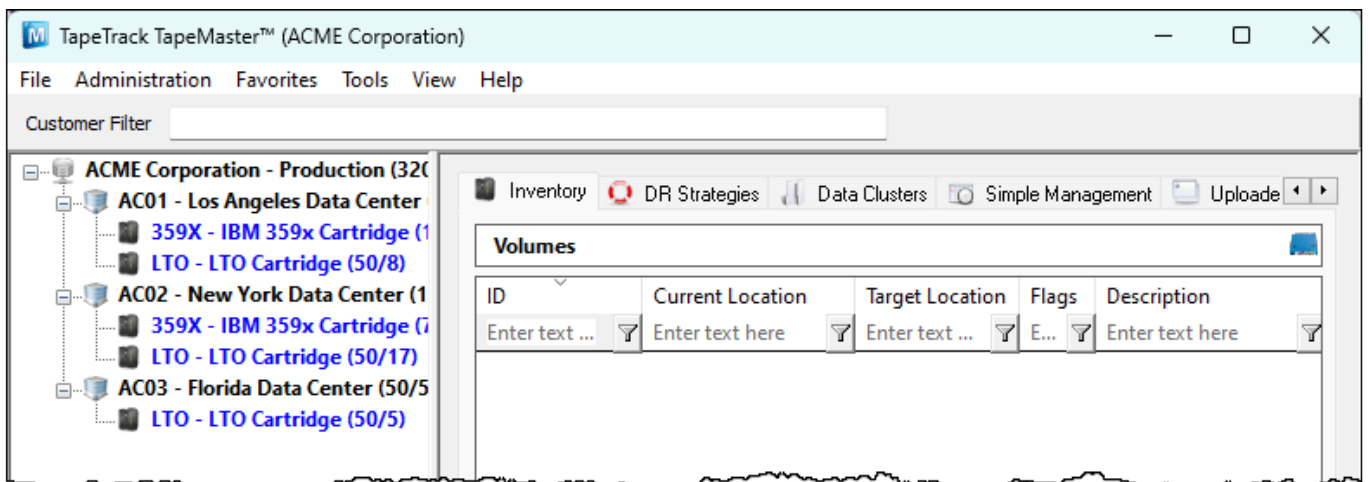

As the business grows and opens new locations, a new Customer is added to TapeMaster for each of them.

Now that we have the Customers added, the next step is to add locations on where the Volumes can be in the Volume movement cycle. The different locations the Volumes can be, are represented in TapeMaster as Repositories. Each Repository depicts one location.

Using Los Angeles as an example, the Volume movement cycle has a Volume taken from a scratch rack and placed in one of two TS3500 Libraries. Once written to the Volumes are vaulted offsite until the data expires and are then transported back to premises. Short term data Volumes are placed back on the scratch rack, while long term data is then stored indefinitely in GemTrac racking.

The Repositories from this scenario are:

- Offsite vault
- Scratch rack
- TS3500 1
- TS3500 2
- GemTrac Racking

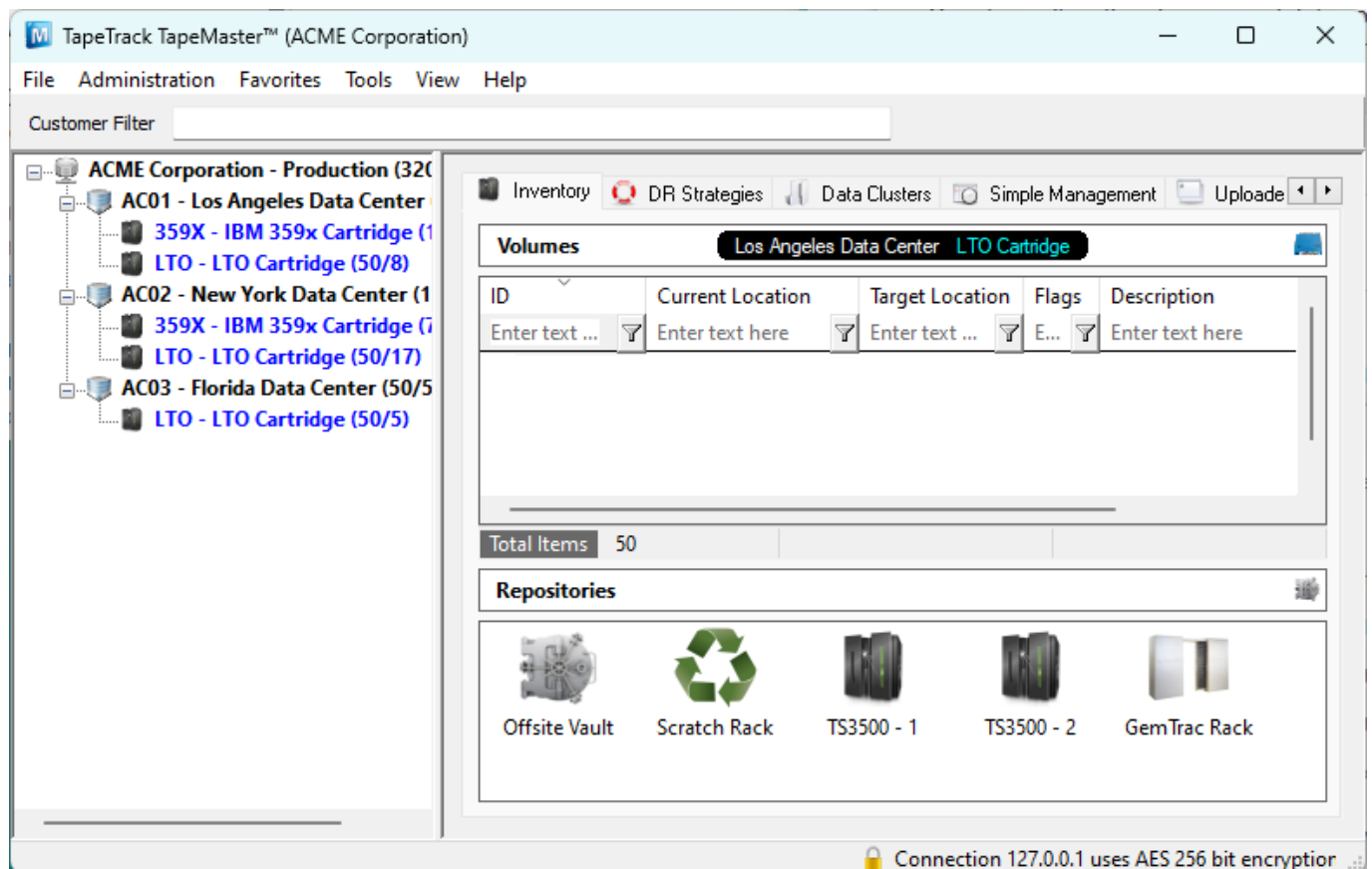

From:  
<https://rtfm.tapetrack.com/> - **TapeTrack Documentation**

Permanent link:  
[https://rtfm.tapetrack.com/planning/tapemaster\\_configuration?rev=1725591313](https://rtfm.tapetrack.com/planning/tapemaster_configuration?rev=1725591313)

Last update: **2025/01/21 22:07**

